

FLUSH CORNER GIRT CONDITIONS

- CD0015 - FLUSH CORNER 8" H.R. GIRT DETAIL
 - CD0090 - FLUSH GIRT TERMINATION DETAIL
 - CD0115 - H.R. GIRT TERMINATION DETAIL
 - CD0116 - HOT-ROLLED GIRT TERMINATION @ C.F. COL.
 - CD0125 - HOT ROLLED GIRT TERMINATION DETAIL
 - CD1010 - FLUSH CORNER WELDED DETAIL
 - CD1020 - FLUSH CORNER COLUMN GIRT DETAIL
 - CD1030 - FLUSH TO FLUSH CORNER DETAIL
-

CD0015 - FLUSH CORNER 8" H.R. GIRT DETAIL

[Download the DWG file by clicking here.](#)

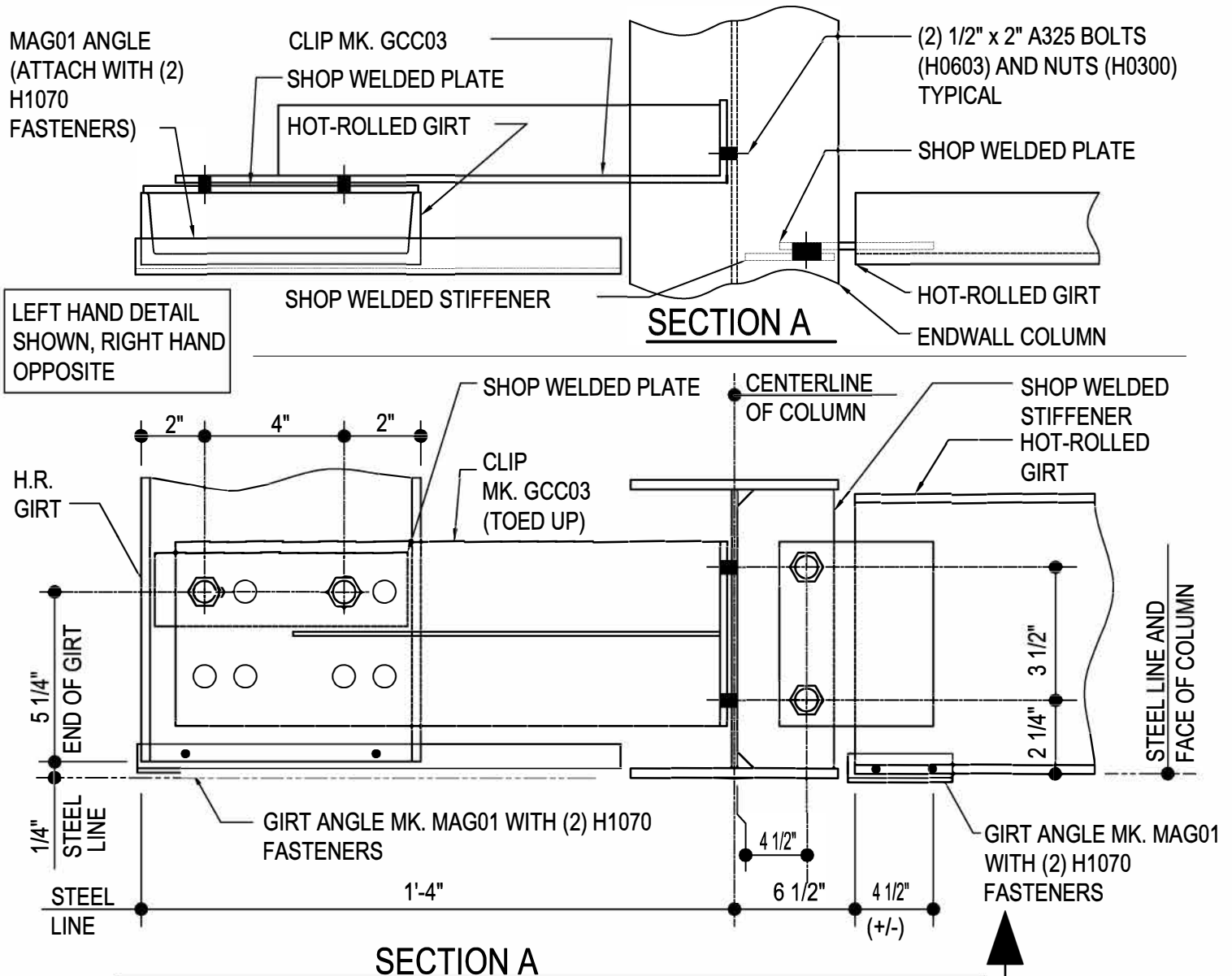

HOT-ROLLED GIRT CORNER DETAIL

8" HOT-ROLLED GIRT AT FLUSH CORNER.

NOTE: USE (6) 1/2" x 2" A325 BOLTS (MK. H0603) & NUTS (MK. H0300)
REFERENCE ERECTOR NOTE FOR TYPICAL WASHER REQUIREMENTS

CD0015

Detailer Notes:

- 1) DETAIL FOR HOT ROLLED & BUILT-UP COLUMN ONLY
- 2) CLIP TO HR GIRT & STIFFENER: GCP06
- 3) STIFFENER TO COLUMN: STFBR
- 4) CLIP TO HR GIRT: HCS08

CD0090 - FLUSH GIRT TERMINATION DETAIL

[Download the DWG file by clicking here.](#)

LEFT HAND DETAIL SHOWN,
RIGHT HAND OPPOSITE

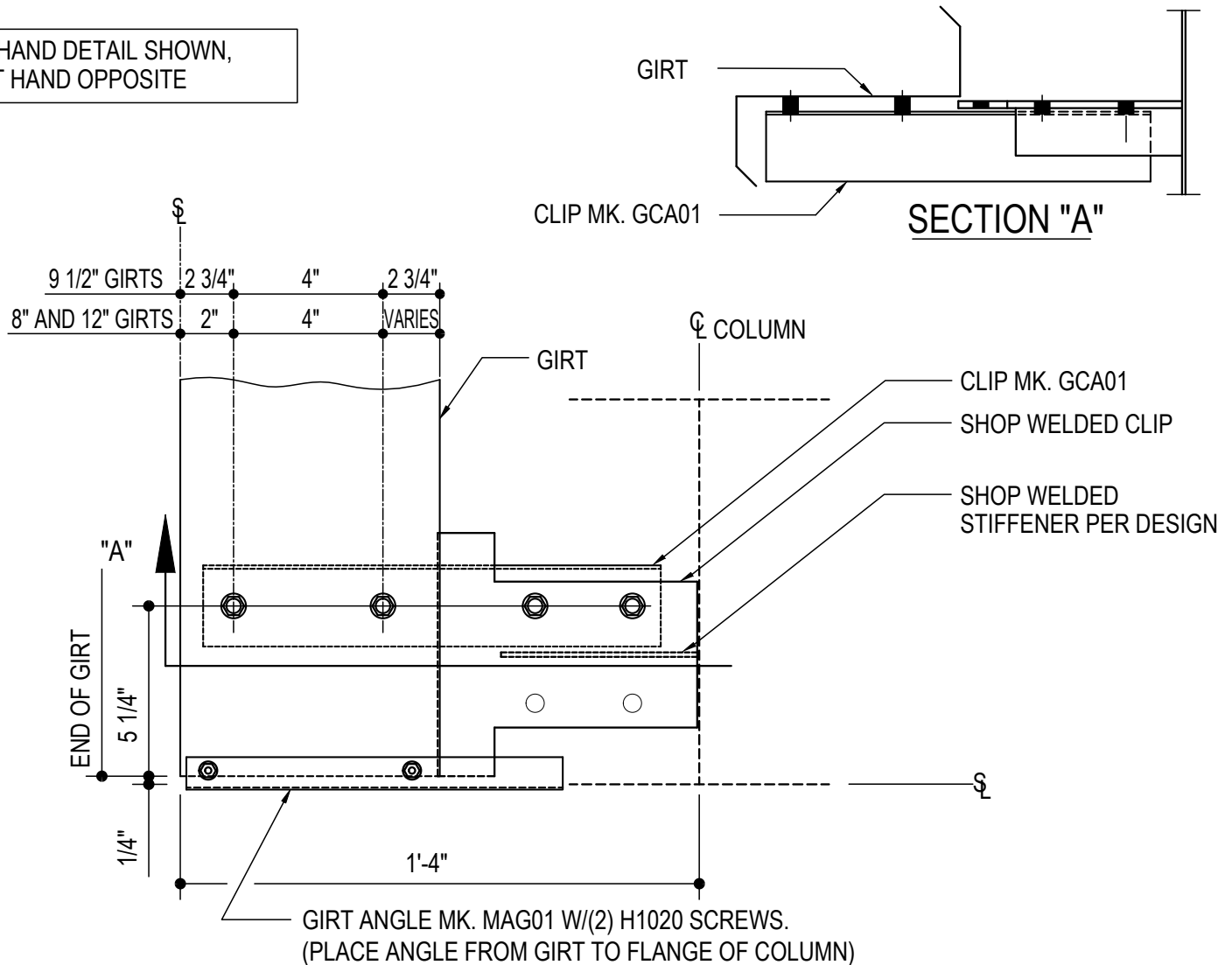

FLUSH GIRT TERMINATION DETAIL

CORNER FLUSH GIRT DETAIL WITH WELDED CLIPS

NOTE: USE (4) 1/2" X 1 1/4" A307 BOLTS H0500/NUTS H0400

REFERENCE WASHER DETAIL FOR TYPICAL WASHER REQUIREMENTS

CD0090

Detailer Notes:

- 1) WELDED CLIP TO COLUMN: GFI02
- 2) ADD STIFFENER PER DESIGN: WS_04

CD0115 - H.R. GIRT TERMINATION DETAIL

[Download the DWG file by clicking here.](#)

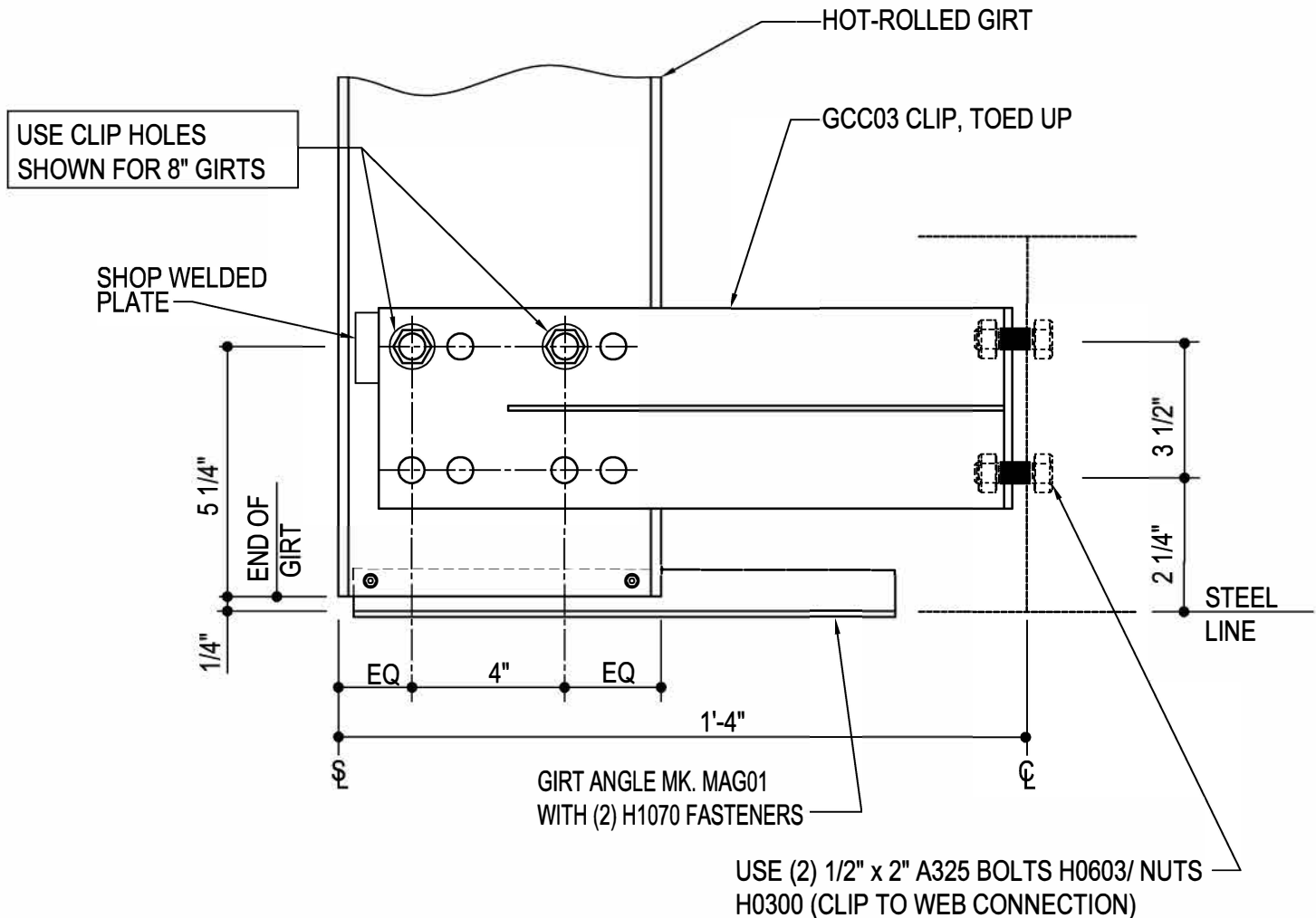

HOT-ROLLED GIRT TERMINATION DETAIL

LEFT HAND DETAIL SHOWN, RIGHT HAND OPPOSITE

NOTE: USE (2) 1/2" x 2" A325 BOLTS (H0603) & NUTS (H0300)

REFERENCE ERECTOR NOTE FOR TYPICAL WASHER REQUIREMENTS

CD0115

Detailer Notes:

- 1) WELDED CLIP TO HR GIRT: HCS08
- 2) DETAIL FOR BU/HR COLUMN ONLY.

CD0116 - HOT-ROLLED GIRT TERMINATION @ C.F. COL.

[Download the DWG file by clicking here.](#)

THESE CLIP HOLES ARE
USED FOR OTHER
APPLICATIONS.

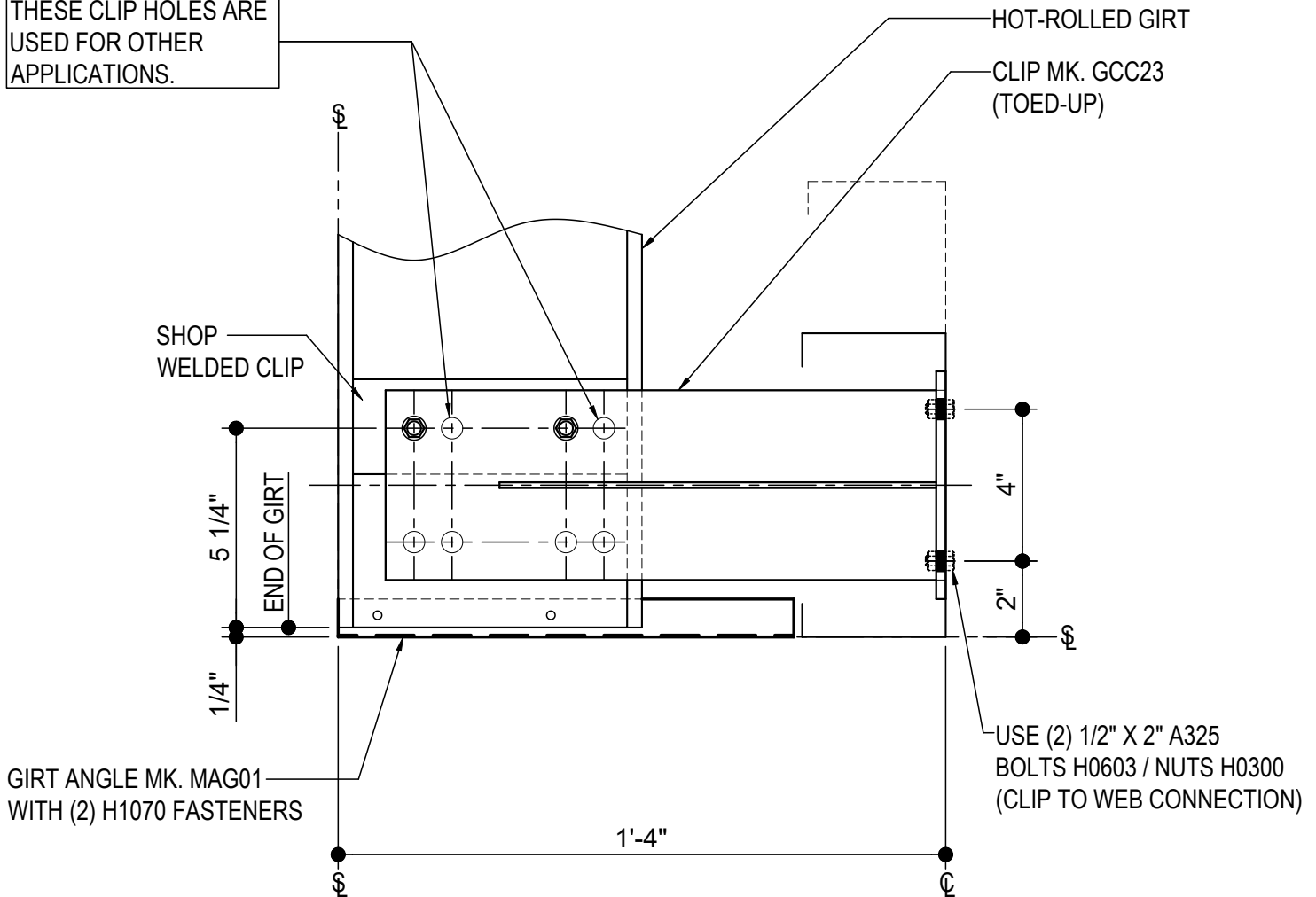

HOT-ROLLED GIRT TERMINATION @ C.F. COL.

LEFT HAND DETAIL SHOWN. RIGHT HAND OPPOSITE

NOTE: USE (2) 1/2" X 2" A325 BOLTS (H0603) & NUTS (H0300)

REFERENCE ERECTOR NOTE FOR TYPICAL WASHER REQUIREMENTS

CD0116

Detailer Notes:

- 1) THIS DETAIL IS FOR COLD FORMED COLUMN CONDITIONS ONLY.
- 2) THE SHOP WELDED CLIP SHOWN IN THE DETAIL, IS A HCS08.

CD0125 - HOT ROLLED GIRT TERMINATION DETAIL

[Download the DWG file by clicking here.](#)

LEFT HAND DETAIL
SHOWN, RIGHT HAND
OPPOSITE

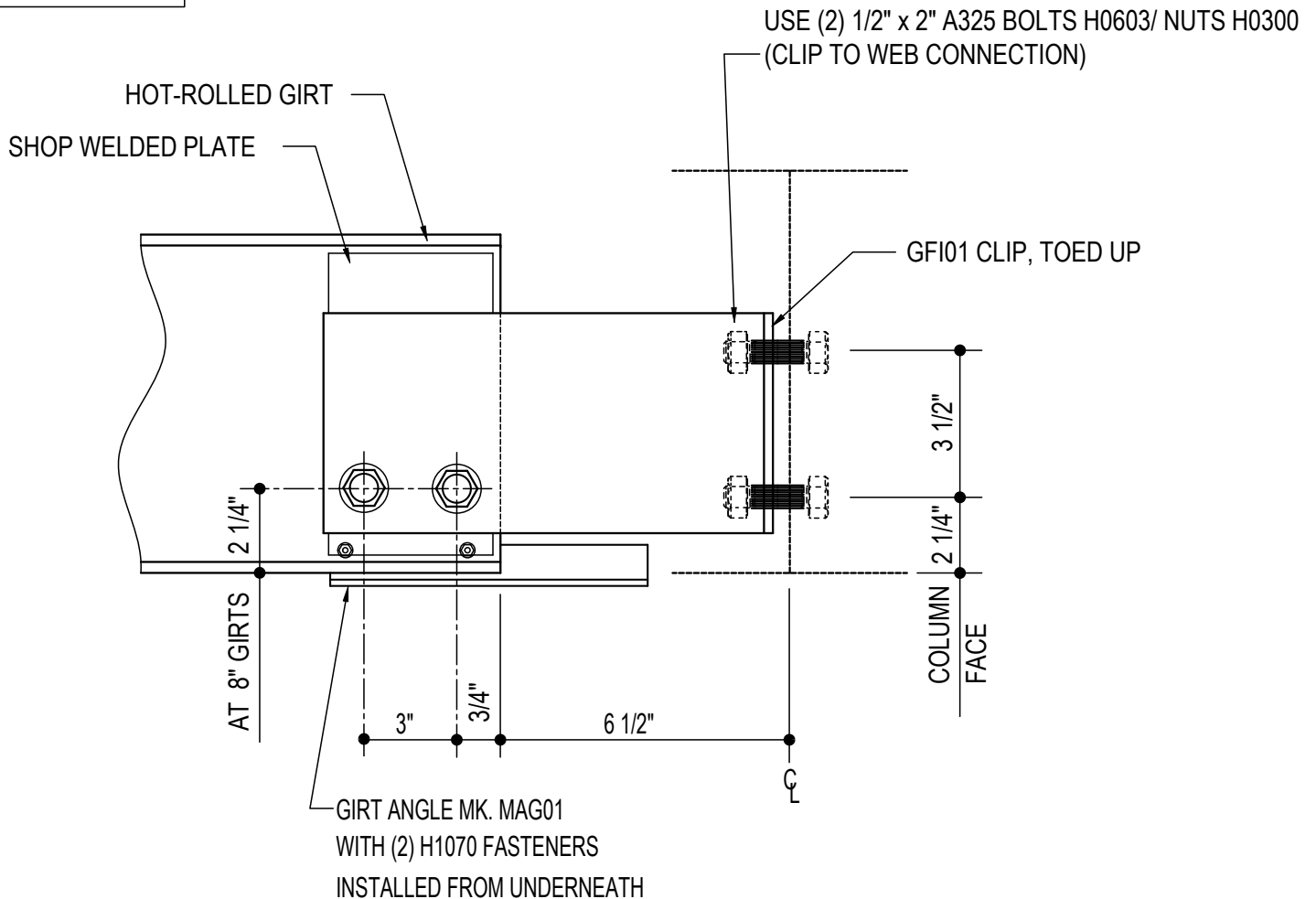

HOT-ROLLED GIRT TERMINATION DETAIL

FLUSH HOT-ROLLED GIRTS

NOTE: USE (2) 1/2" x 2" A325 BOLTS (H0603) & NUTS (H0300)

REFERENCE STANDARD WASHER DETAIL FOR TYPICAL WASHER REQUIREMENTS

CD0125

Detailer Notes:

- 1) WELDED CLIP TO HR GIRT: HCD08
- 2) DETAIL IS FOR BU/HR COLUMN ONLY.

CD1010 - FLUSH CORNER WELDED DETAIL

[Download the DWG file by clicking here.](#)

LEFT HAND DETAIL SHOWN,
RIGHT HAND OPPOSITE

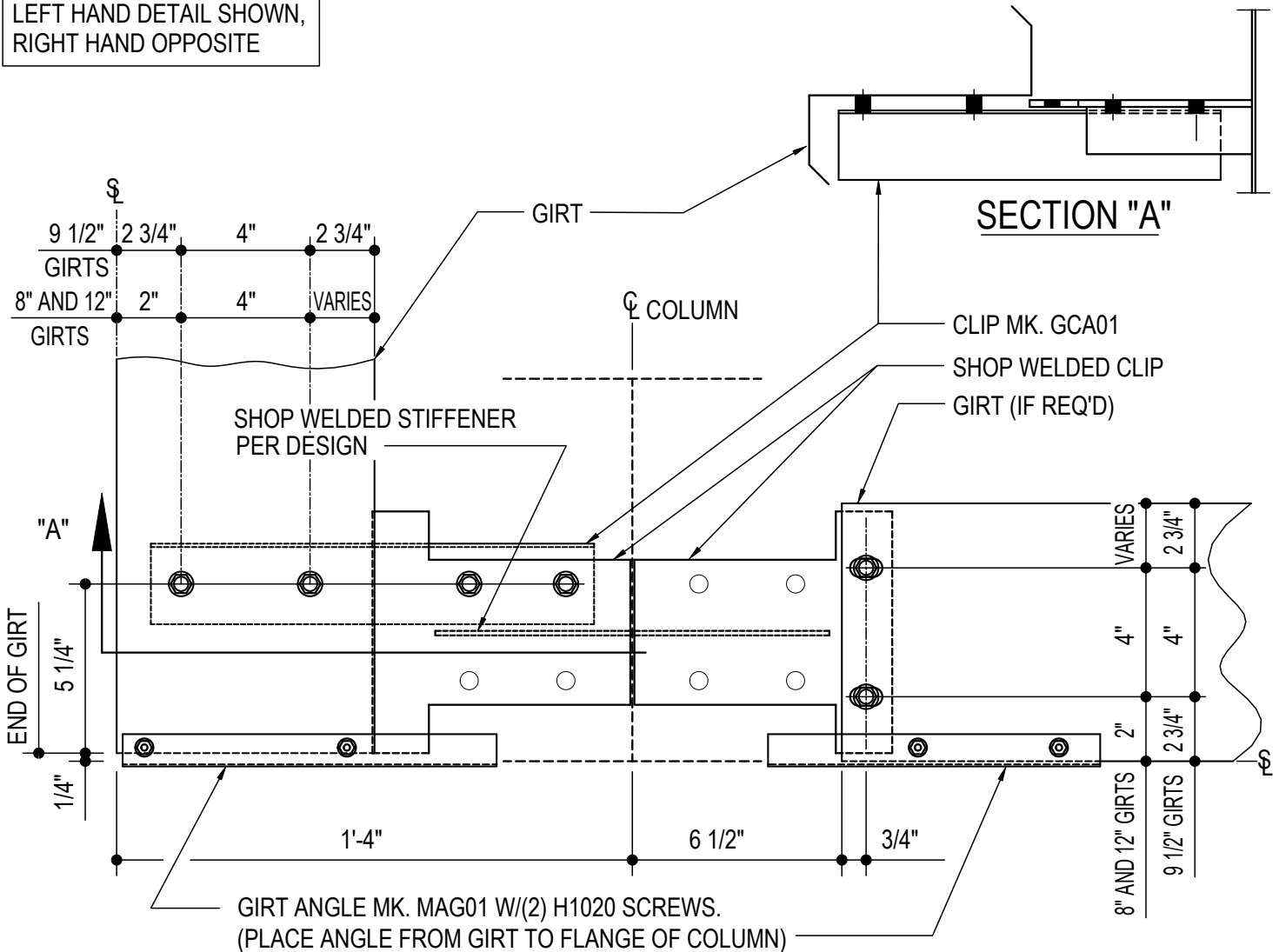

CORNER GIRT DETAIL

CORNER FLUSH GIRT DETAIL WITH WELDED CLIPS

NOTE: USE (6) 1/2" X 1 1/4" A307 BOLTS H0500/NUTS H0400

REFERENCE WASHER DETAIL FOR TYPICAL WASHER REQUIREMENTS

CD1010

Detailer Notes:

- 1) WELDED CLIP TO COLUMN: GFI02
- 2) ADD STIFFENER PER DESIGN: WS_04

CD1020 - FLUSH CORNER COLUMN GIRT DETAIL

[Download the DWG file by clicking here.](#)

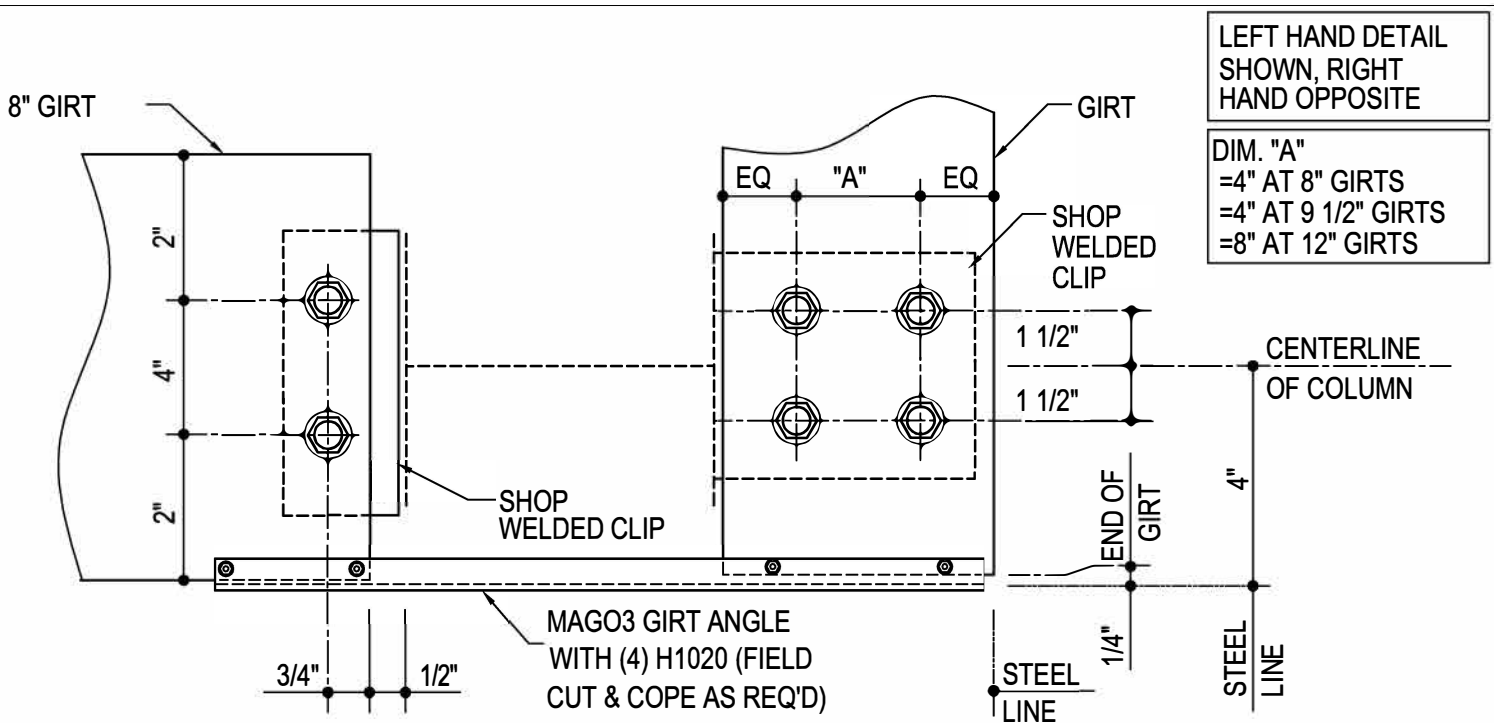
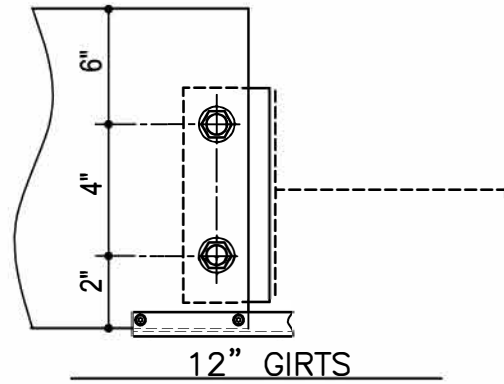
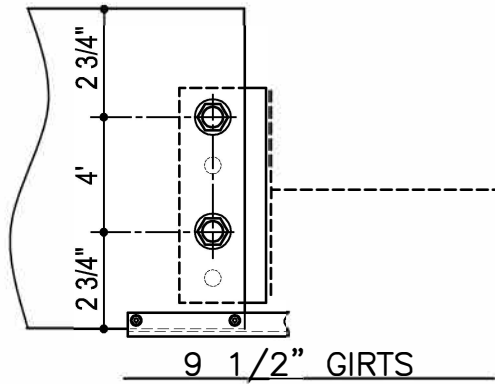

LEFT HAND DETAIL
SHOWN, RIGHT
HAND OPPOSITE

DIM. "A"
=4" AT 8" GIRTS
=4" AT 9 1/2" GIRTS
=8" AT 12" GIRTS

FLUSH CORNER COLUMN GIRT DETAIL

NOTE: USE (6) 1/2" x 1 1/4" A307 BOLTS H0500/NUTS H0400
REFERENCE STANDARD WASHER DETAIL FOR TYPICAL
WASHER REQUIREMENTS

CD1020

Detailer Notes:

- | | |
|---|---|
| 1) (4) HOLE WELDED CLIP:
8" - PCU01
9 1/2" - GCB62
12" - GCB12 | 2) (2) HOLE WELDED CLIP:
8" - GRC03
9 1/2" - GRC09
12" - GRC03 |
|---|---|

CD1030 - FLUSH TO FLUSH CORNER DETAIL

[Download the DWG file by clicking here.](#)

ERECTOR NOTE

GIRT CLIPS ARE FACTORY PUNCHED TO BE USED WITH MULTIPLE GIRT DEPTHS. REFER TO THE STANDARD BOLT PLACEMENT DETAIL(S) FOR PROPER BOLT PLACEMENT.

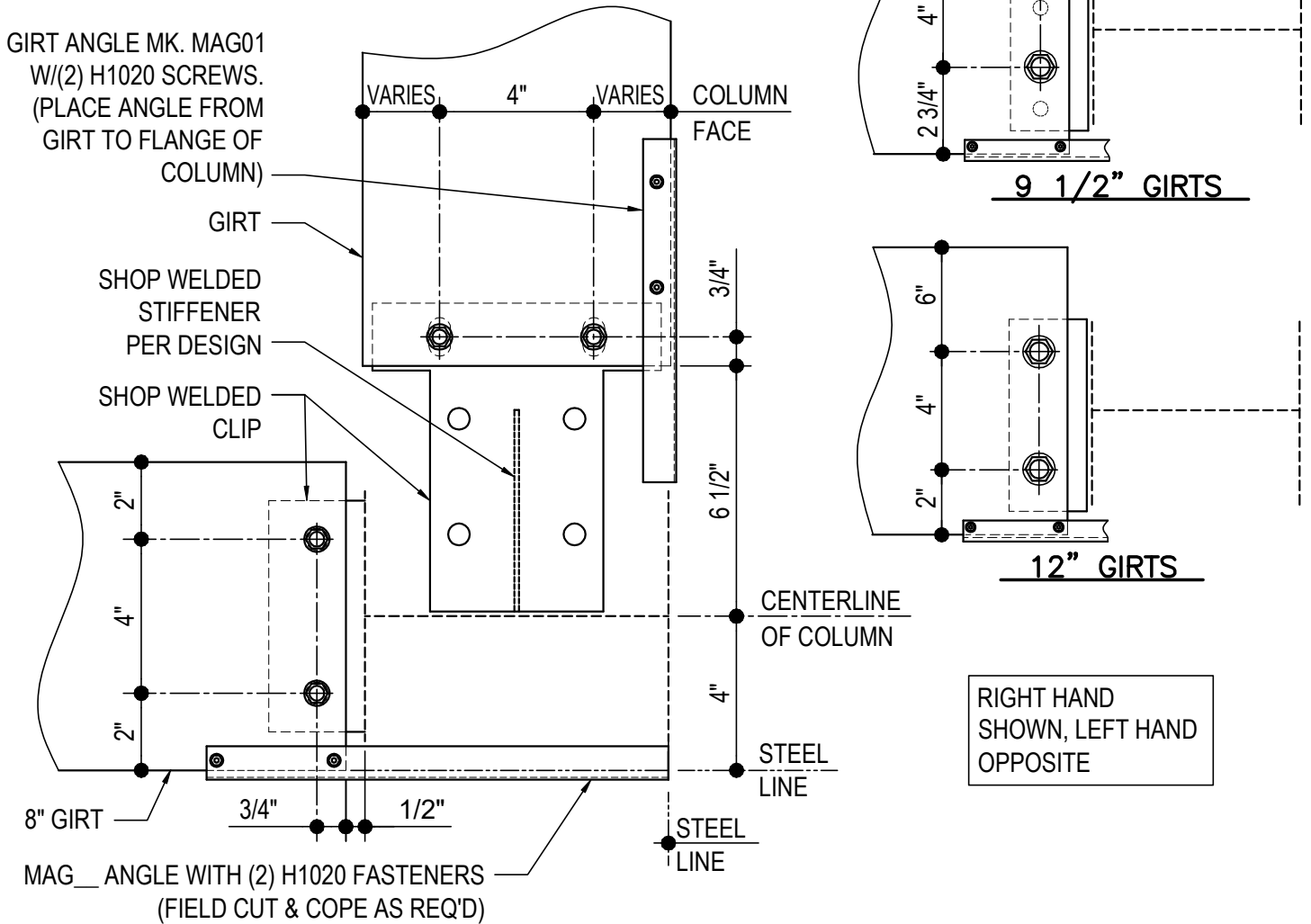

FLUSH TO FLUSH CORNER DETAIL

NOTE: USE (4) 1/2"x 1 1/4" A307 BOLTS H0500/NUTS H0400
REFERENCE STANDARD WASHER DETAIL FOR TYPICAL WASHER REQUIREMENTS

CD1030

Detailer Notes:

- 1) (2) HOLE WELDED CLIP: GRC03 (AT 8" AND 12" GIRTS), GRC09 (AT 9 1/2" GIRTS)
- 2) WELDED CLIP AT COLUMN WEB: GFI02
- 3) ADD STIFFENER PER DESIGN WS_04